

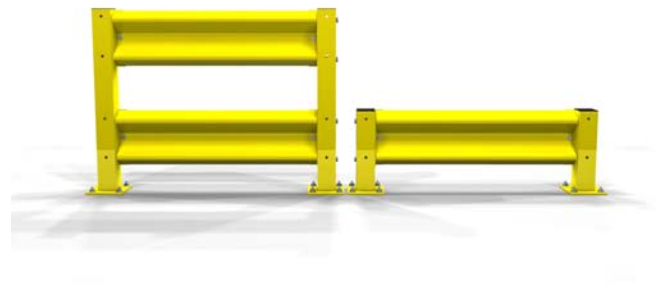

Guardrail Installation Instructions

Tool List Needed for Installation

1. Hammer drill with 5/8" carbide concrete bit.
2. Hammer
3. Crescent Wrench
4. Chalk Line



TUFGUARD GUARDRAIL PARTS LEGEND

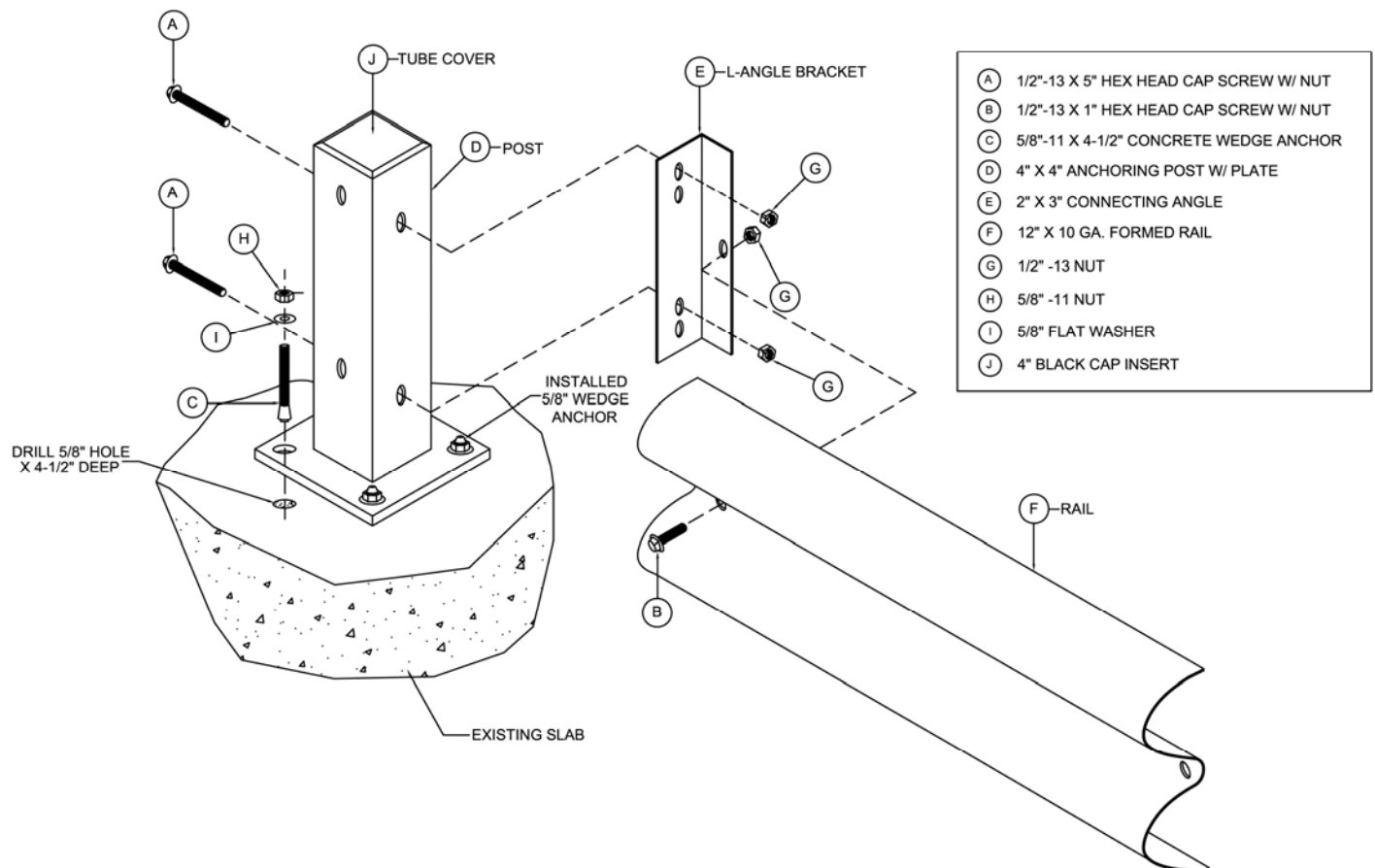

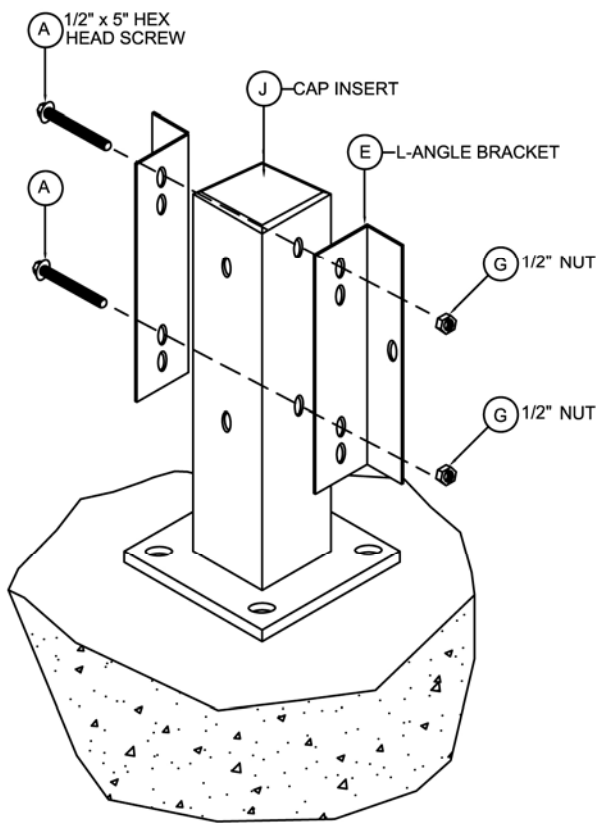

INTERMEDIATE POST

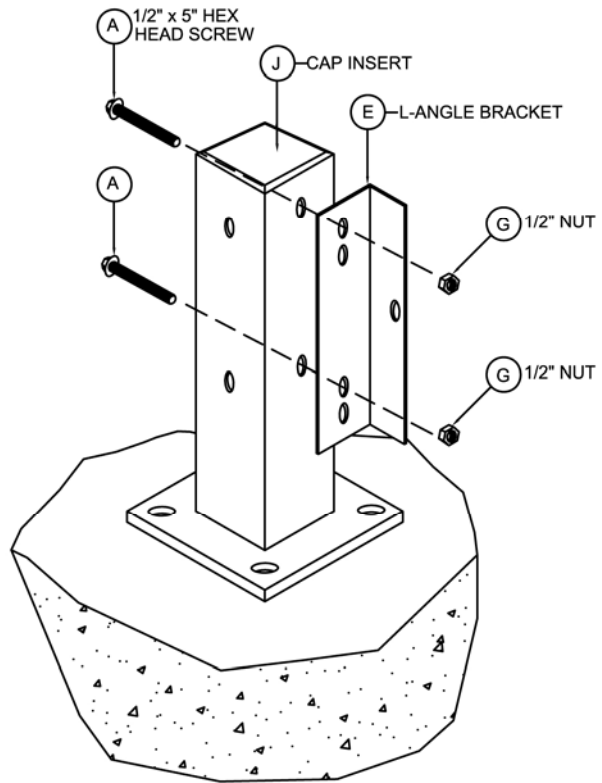

END POST

Step 1

Unpack all posts and insert post caps.

Attach the L-Angle Bracket using supplied 1/2" x 5" hex head bolts (2) per bracket.

End posts will only have (1) L-Angle bracket attached, intermediate and corner posts will have (2) L-Angle brackets attached.

Refer to your layout drawing for configurations of posts.

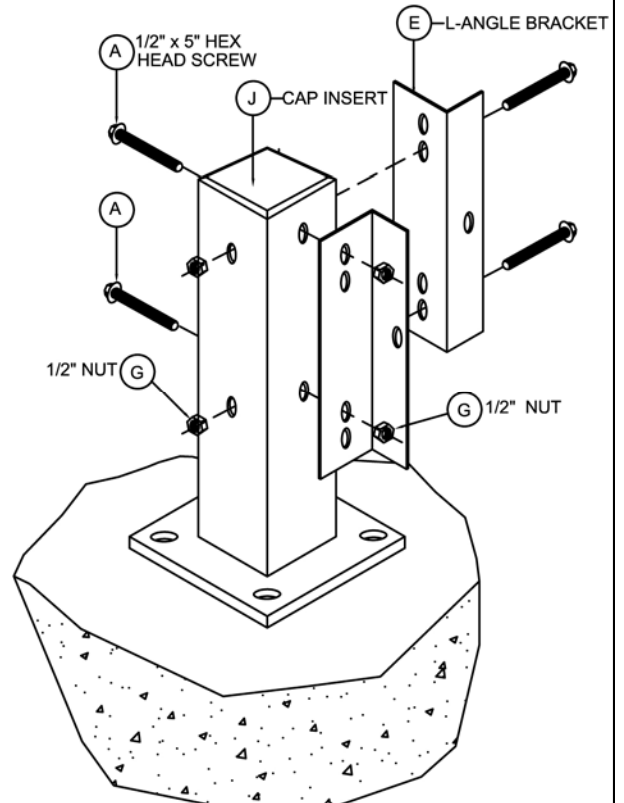

CORNER POST

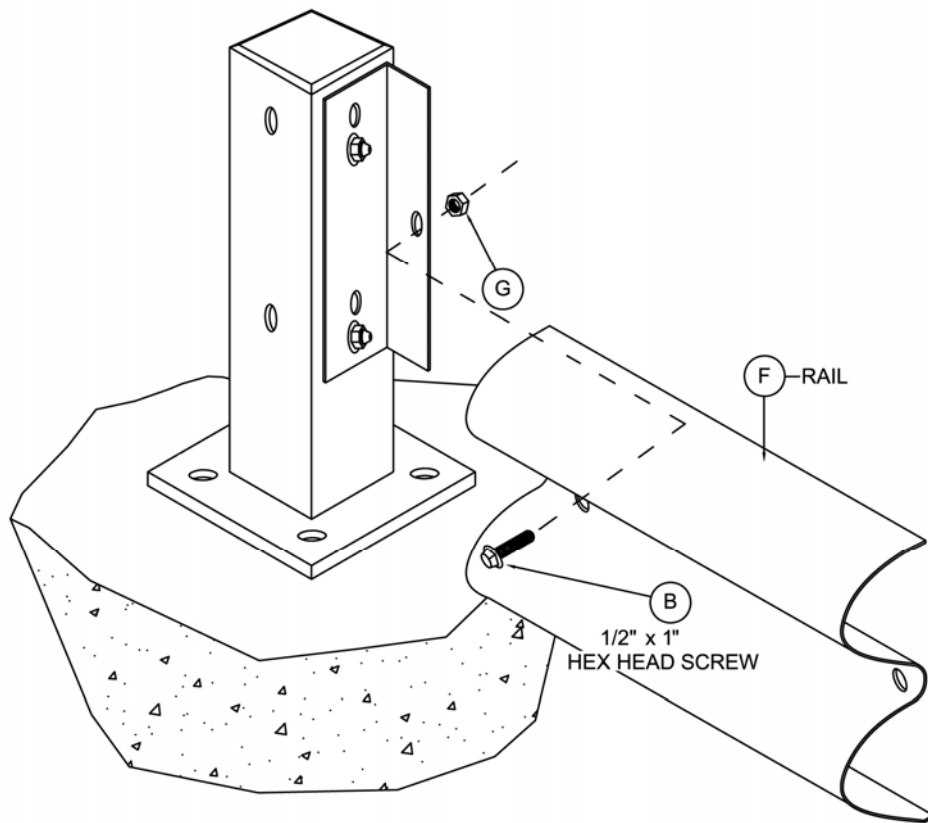

Step 2

Attach Rails to L-Angle brackets using supplied 1/2" x 1" hex head bolts. Move completed sections into their final position for anchoring.

Note: Guardrail is typically installed a minimum of 6" from walls or equipment for maximum protection.

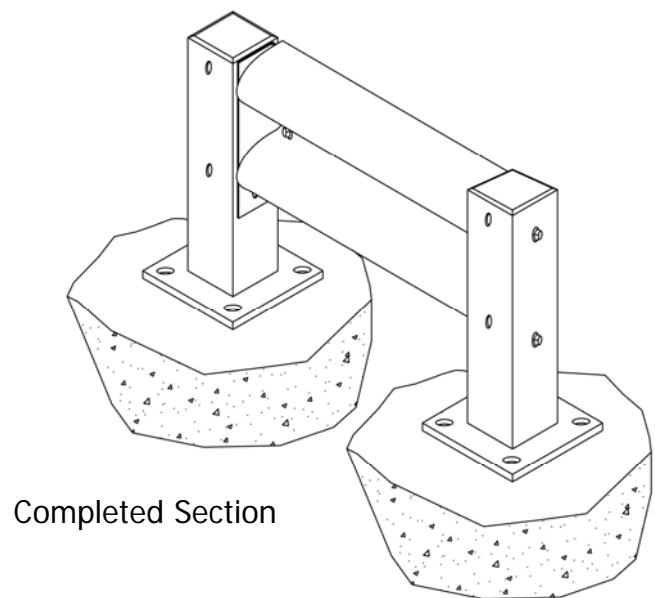

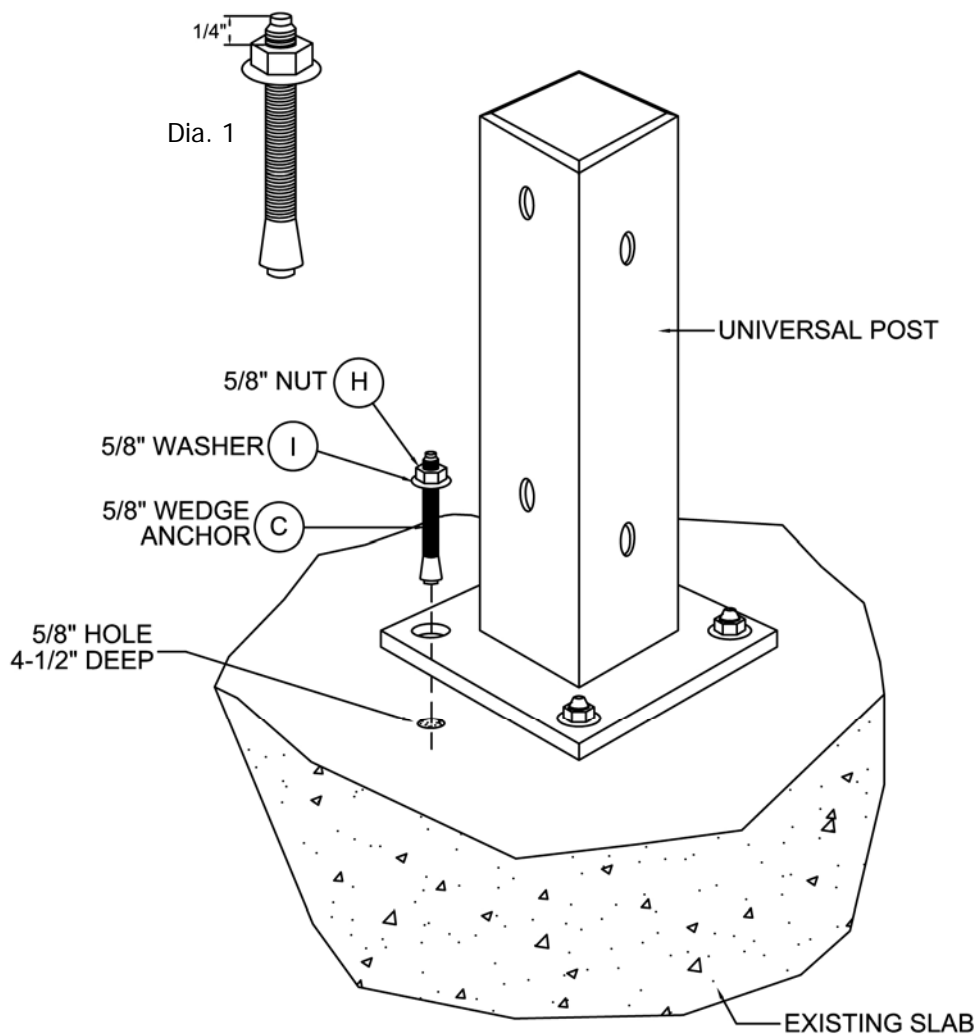

Step 3

Using hammer drill with 5/8" concrete bit and guardrail footplate as template, drill four holes approximately 4-1/2" deep. Sweep under footplate to remove any debris that might keep post from sitting level.

Place 5/8" washer and 5/8" nut on anchors approximately 1/4" below top of threads as shown in dia. 1 above.

Place anchors through footplate and into concrete as shown above and hammer down until only about 3/4" of anchor is showing above footplate and tighten.